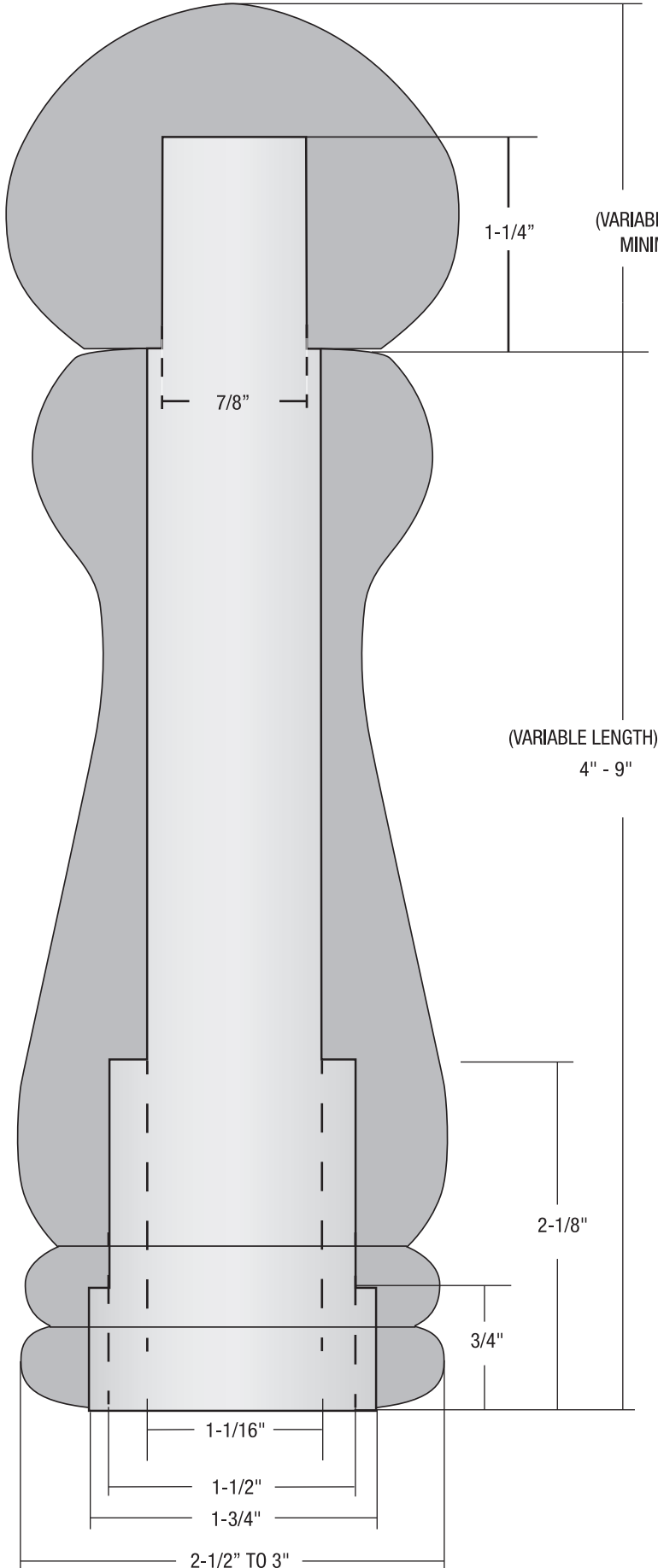

Diagram A - Boring the Blanks



PKGRINDTL Instructions

Pro-Grind Variable Length Peppermill with Stem



Required Accessories

- **FB78** 7/8" Forstner bit
- **FB1-116** 1-1/6" Forstner bit
- **FB150** 1-1/2" Forstner bit
- **FB134** 1-3/4" Forstner bit
- **FEX** 4" Forstner bit extender
- **CJAM15** - 1-1/2" Jam Chuck (requires a drill chuck)

Required Wood

- Base blank - 4" (minimum) to 9" (maximum) length by 2-1/2" to 3" square depending on your design.
- Head blank - 2" min length by 2-1/2" to 3" sq depending on design.

Boring the Blanks (see Diagram A)

- Base blank - Locate the center of the blank and bore sequential holes:
 1. Bore a 1-3/4" hole to 3/4" deep
 2. Bore a 1-1/2" hole to 2-1/8" total depth
 3. Bore a 1-1/16" hole through (use drill bit extender)
- Head blank - Locate the center of the blank and bore a 7/8" hole to 1-1/4" deep

Diagram B - Turning the Base Blank

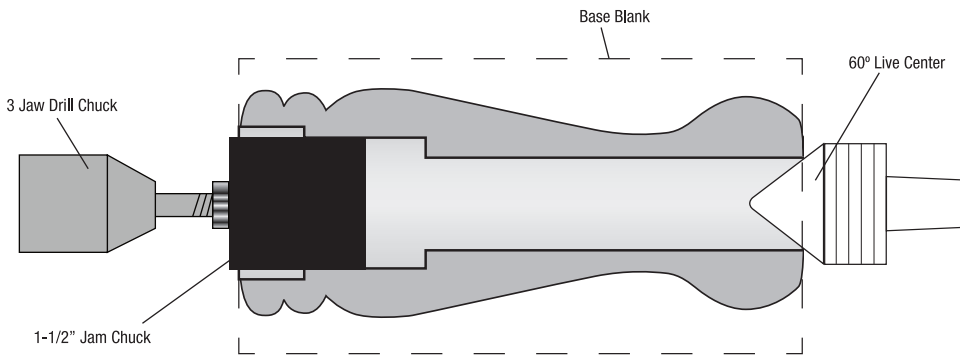

Diagram B2 - Turning the Head Blank

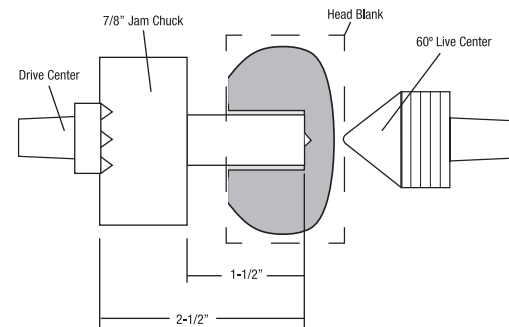
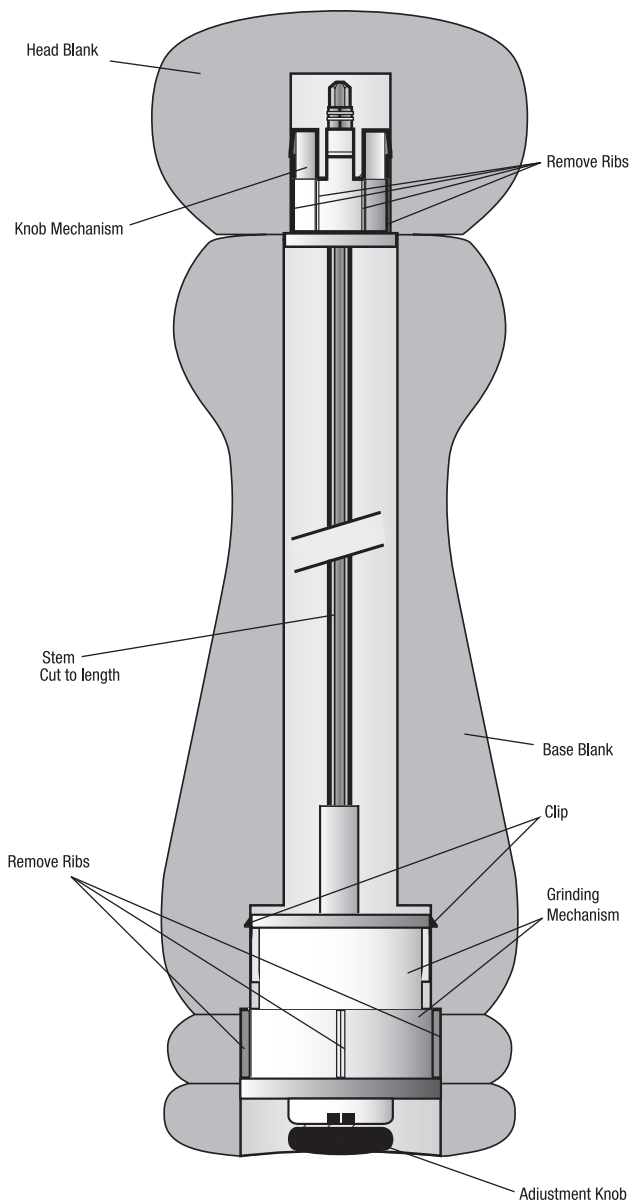

Diagram C - Assembly



Turning the Blanks

Base Blank - Use a jam chuck to 1-1/2" diameter. Insert into the base blank and mount over the lathe.

- Support opposite end using a large live center. (See Diagram B1)
- Turn a profile, sand, and finish the wood.

Head Blank - Make a jam chuck 7/8" diameter.

(See Diagram B2)

- Insert into head blank.
- Mount over the lathe.
- Support with live center.
- Turn a profile and finish the wood.

Assembly (see Diagram C)

- NOTE: The mechanism is designed to fit in metric holes. In order to fit in standard holes, some modifications to the mechanisms are necessary.
- Remove the 6 ribs over the surface of the grinding mechanism and the knob mechanism.
- Remove the edge of the clips (if necessary).
- Trim the stem to adjust to the length of the wooden base you have chosen.
- Insert mechanisms prior to gluing to check fit, centering, and stem length.
- Use glue carefully (avoid any moving parts) over surface of the grinding mechanism.
- Insert and press the grinding mechanism firmly into the 1-1/2" hole in the base blank.
- Glue over the outer surface of the knob mechanism. Insert and press into the head blank.
- When glue dries, insert the head over the stem. The stem should penetrate the sleeve in the knob mechanism.
- To adjust the coarseness of the grind, just twist the adjustment knob in or out.